

HC3415

20V P-Channel MOSFET

General Description

These P-Channel enhancement mode power field effect transistors are using trench DMOS technology. This advanced technology has been especially tailored to minimize on-state resistance, provide superior switching performance, and withstand high energy pulse in the avalanche and commutation mode. These devices are well suited for high efficiency fast switching applications.

Features

V_{DS}	-20V
I_D (at $V_{GS}=-4.5V$)	-5.0A
$R_{DS(ON)}$ (at $V_{GS}=-4.5V$)	40mΩ(Max)

ESD protected

SOT23

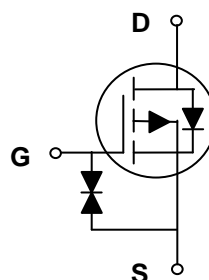
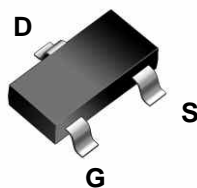

Absolute Maximum Ratings $T_A=25^\circ C$ unless otherwise noted

Parameter	Symbol	Maximum	Units	
Drain-Source Voltage	V_{DS}	-20	V	
Gate-Source Voltage	V_{GS}	±12	V	
Drain Current-Continuous	TC=25°C	I_D	-5.0	A
	TC=100°C	I_D	-3.5	A
Maximum Power Dissipation	P_D	1.3	W	
Drain Current – Pulsed1	I_{DM}	-20	A	
Junction and Storage Temperature Range	T_J, T_{STG}	-55 To 150	°C	

Thermal Characteristics

Parameter	Symbol	Typ	Max	Unit
Thermal Resistance junction-case	$R_{\theta Jc}$		1.1	°C /W
Thermal Resistance unction-to-Ambient	$R_{\theta JA}$		60	°C /W

Electrical Characteristics (T_J=25°C unless otherwise noted)

Symbol	Parameter	Condition	Min	Typ	Max	Unit
STATIC PARAMETERS						
BV _{DSS}	Drain-Source Breakdown Voltage	V _{GS} =0V, I _D =-250μA	-20			V
I _{DSS}	Zero Gate Voltage Drain Current	V _{DS} =-20V, V _{GS} =0V			1	μA
I _{GSS}	Gate-Body Leakage Current	V _{GS} =±10V, V _{DS} =0V			±10	μA
V _{GS(th)}	Gate Threshold Voltage	V _{DS} =V _{GS} , I _D =-250μA	-0.3	-0.6	-1.0	V
R _{DS(ON)}	Drain-Source On-State Resistance	V _{GS} =-4.5V, I _D =-5.0A		30	40	mΩ
		V _{GS} =-2.5V, I _D =-4.0A		35	50	mΩ
		V _{GS} =-1.8V, I _D =-3.0A		50	70	mΩ
DYNAMIC PARAMETERS						
C _{ISS}	Input Capacitance	V _{DS} =-10V, V _{GS} =0V, F=1.0MHz		950		pF
C _{OSS}	Output Capacitance			200		pF
C _{RSS}	Reverse Transfer Capacitance			160		pF
SWITCHING PARAMETERS						
t _{d(on)}	Turn-on Delay Time	V _{DD} =-10V, I _D =-1A, V _{GS} =-4.5V, R _G =3Ω		9.5		nS
t _r	Turn-on Rise Time			17		nS
t _{d(off)}	Turn-Off Delay Time			90		nS
t _f	Turn-Off Fall Time			30		nS
Q _g	Total Gate Charge	V _{DS} =-10V, I _D =-4A, V _{GS} =-4.5V		17		nC
Q _{gs}	Gate-Source Charge			1.3		nC
Q _{gd}	Gate-Drain Charge			4.5		nC
V _{SD}	Diode Forward Voltage	V _{GS} =0V, I _{SD} =-1A		0.72	1.2	V

Note:

1. Repetitive Rating : Pulsed width limited by maximum junction temperature.
2. The data tested by pulsed , pulse width ≅ 300us , duty cycle ≅ 2%.
3. Essentially independent of operating temperature.

TYPICAL ELECTRICAL AND THERMAL CHARACTERISTICS

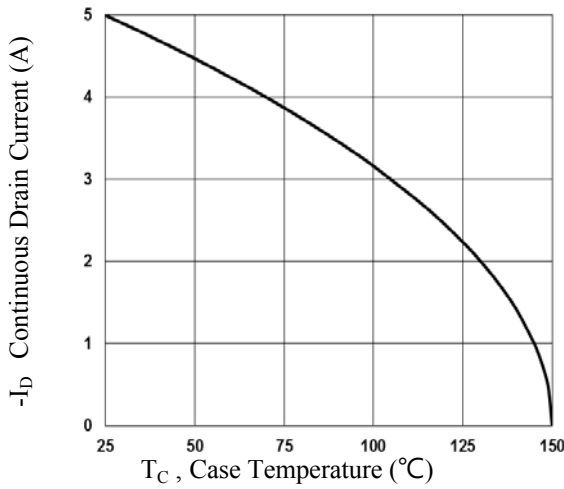

Fig.1 Typical Output Characteristics

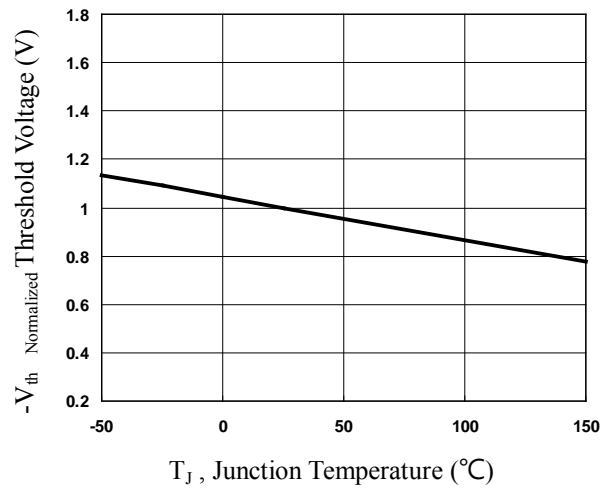

Fig.2 Normalized Vth vs. Junction Temperature

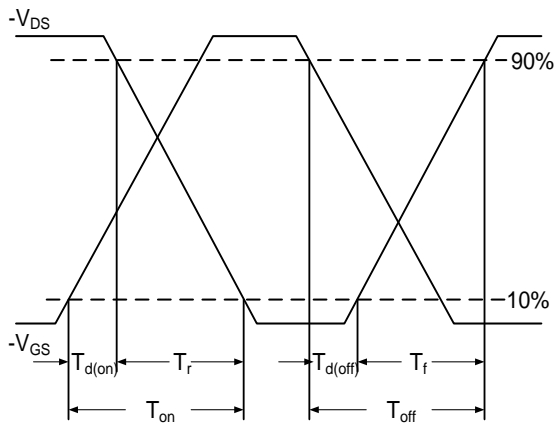

Fig.3 Switching Time Waveform

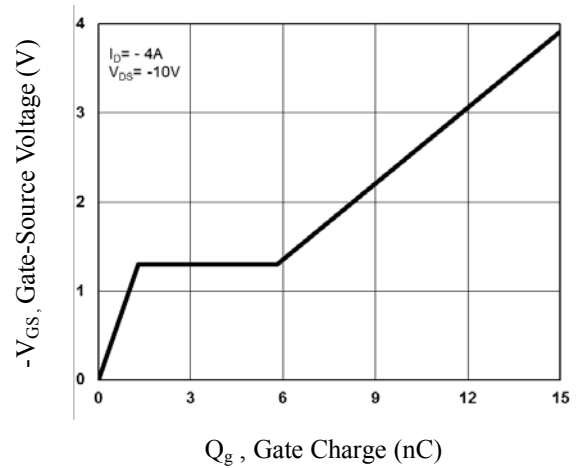

Fig.4 Gate Charge Waveform

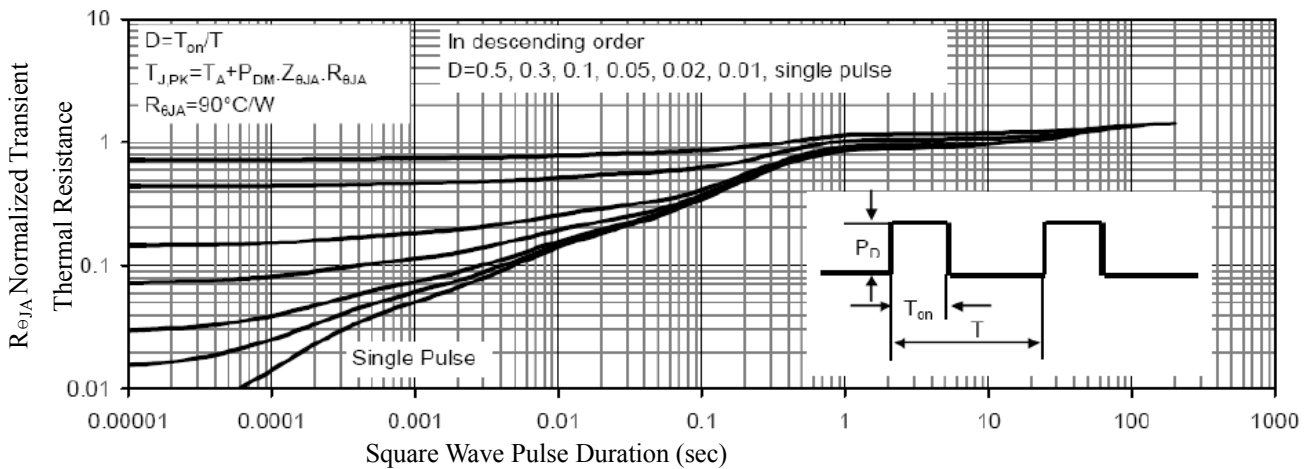
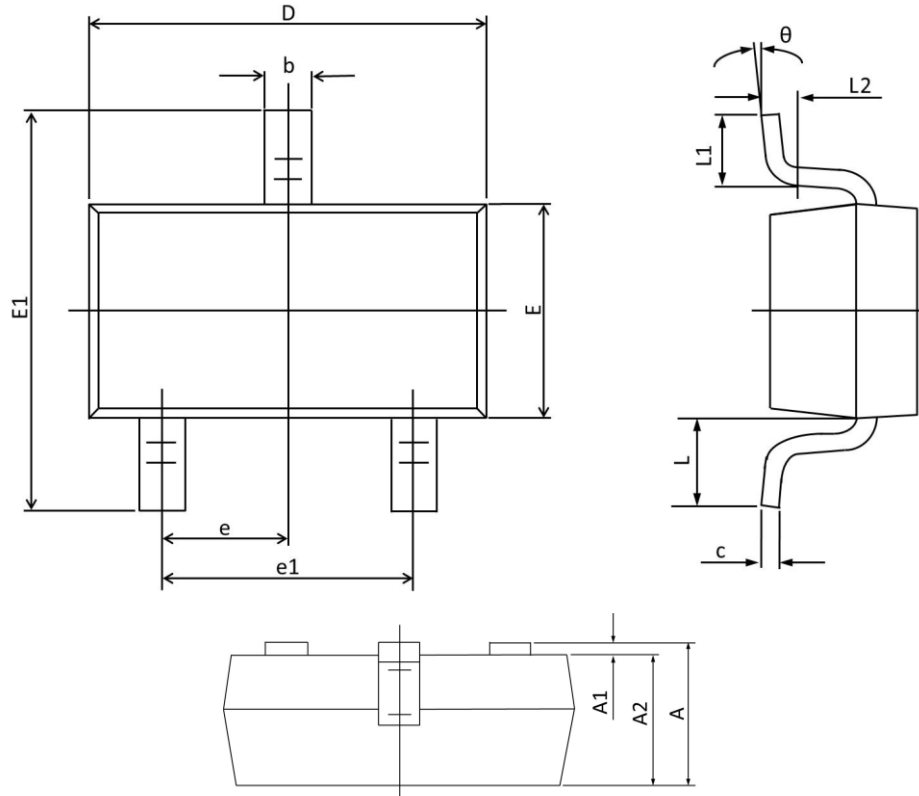

Fig.5 Normalized Maximum Effective Transient Thermal Impedance

SOT23 PACKAGE INFORMATION



Symbol	Dimensions In Millimeters		Dimensions In Inches	
	Max	Min	Max	Min
A	1.150	0.900	0.045	0.035
A1	0.100	0.000	0.004	0.000
A2	1.050	0.900	0.041	0.035
b	0.500	0.300	0.020	0.012
c	0.150	0.080	0.006	0.003
D	3.000	2.800	0.118	0.110
E	1.400	1.200	0.055	0.047
E1	2.550	2.250	0.100	0.089
e	0.95 TYP.		0.037 TYP.	
e1	2.000	1.800	0.079	0.071
L	0.55 REF.		0.022 REF.	
L1	0.500	0.300	0.020	0.012
L2	0.25 TYP.		0.01 TYP.	
θ	8°	0°	8°	0°