

HC2300

20V N-Channel MOSFET

General Description

The HC2300 combines advanced trench MOSFET technology with a low resistance package to provide extremely low $R_{DS(ON)}$. This device is suitable for use as a load switch or in PWM applications.

Features

V_{DS}	20V
I_D (at $V_{GS}=4.5V$)	4.5A
$R_{DS(ON)}$ (at $V_{GS}=4.5V$)	25mΩ(Max)

SOT23

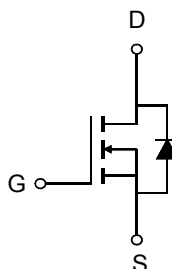
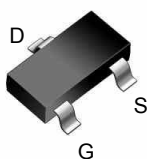

Absolute Maximum Ratings $T_A=25^\circ C$ unless otherwise noted

Parameter	Symbol	Maximum	Units	
Drain-Source Voltage	V_{DS}	20	V	
Gate-Source Voltage	V_{GS}	±12	V	
Drain Current-Continuous	TC=25°C	I_D	4.5	A
	TC=100°C	I_D	2.7	A
Drain Current – Pulsed	I_{DM}	18	A	
Maximum Power Dissipation	P_D	1.56	W	
Junction and Storage Temperature Range	T_J, T_{STG}	-55 To 150	°C	

Thermal Characteristics

Parameter	Symbol	Typ	Max	Unit
Thermal Resistance junction-case	$R_{\theta Jc}$		1.1	°C /W
Thermal Resistance junction-to-Ambient	$R_{\theta JA}$		62	°C /W

Electrical Characteristics (T_J=25°C unless otherwise noted)

Symbol	Parameter	Condition	Min	Typ	Max	Unit
STATIC PARAMETERS						
BV _{DSS}	Drain-Source Breakdown Voltage	V _{GS} =0V, I _D =250μA	20			V
I _{DSS}	Zero Gate Voltage Drain Current	V _{DS} =20V, V _{GS} =0V			1	μA
I _{GSS}	Gate-Body Leakage Current	V _{GS} =±12V, V _{DS} =0V			±100	nA
V _{GS(th)}	Gate Threshold Voltage	V _{DS} =V _{GS} , I _D =250μA	0.45	0.65	1.0	V
R _{DS(ON)}	Drain-Source On-State Resistance	V _{GS} =4.5V, I _D =3.0A		19	25	mΩ
		V _{GS} =2.5V, I _D =2.0A		25	32	mΩ
		V _{GS} =1.8V, I _D =2.7A		33	49	mΩ
gfs	Forward Transconductance	V _{DS} =5V, I _D =4.5A		10		S
DYNAMIC PARAMETERS						
C _{iSS}	Input Capacitance	V _{DS} =10V, V _{GS} =0V, F=1.0MHz		420		pF
C _{oSS}	Output Capacitance			60		pF
C _{rSS}	Reverse Transfer Capacitance			34		pF
SWITCHING PARAMETERS						
t _{d(on)}	Turn-on Delay Time	V _{GS} =4.5V V _{DS} =10V R _G =25Ω I _D =1A		4.1		nS
t _r	Turn-on Rise Time			11.6		nS
t _{d(off)}	Turn-Off Delay Time			23.9		nS
t _f	Turn-Off Fall Time			7.6		nS
Q _g	Total Gate Charge	V _{DS} =10V, I _D =4A, V _{GS} =4.5V		7.7		nC
Q _{gs}	Gate-Source Charge			0.9		nC
Q _{gd}	Gate-Drain Charge			2.4		nC
V _{SD}	Diode Forward Voltage	V _{GS} =0V, I _{SD} =1A		0.70	1.3	V

Note:

1. Repetitive Rating : Pulsed width limited by maximum junction temperature.
2. The data tested by pulsed , pulse width ≅ 300us , duty cycle ≅ 2%.
3. Essentially independent of operating temperature.

TYPICAL ELECTRICAL AND THERMAL CHARACTERISTICS

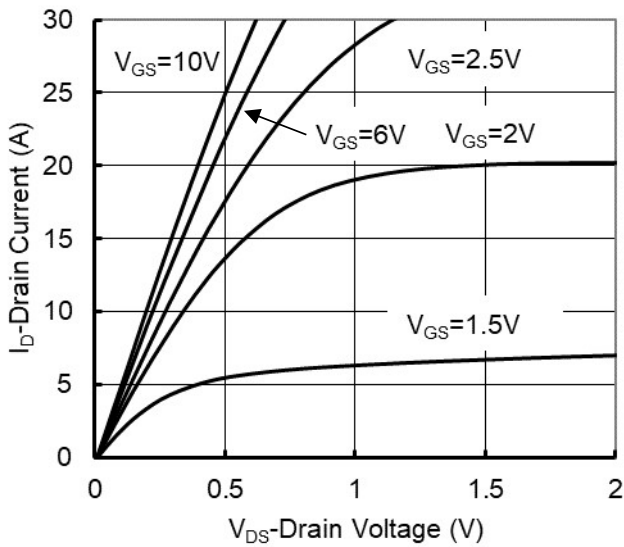

Figure1. Output Characteristics

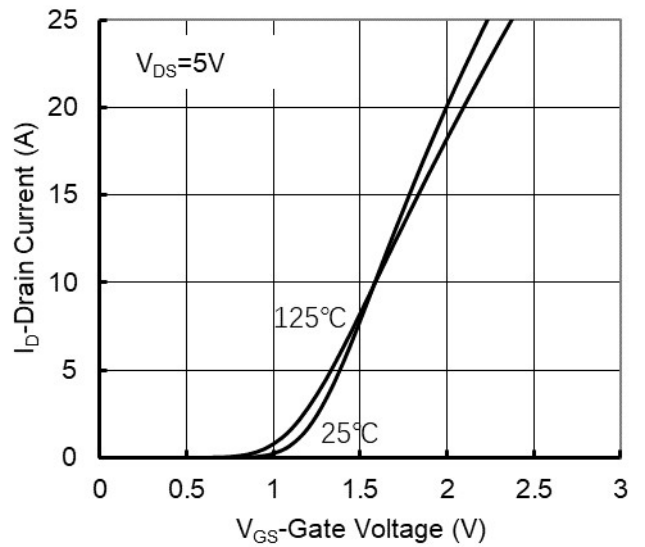

Figure2. Transfer Characteristics

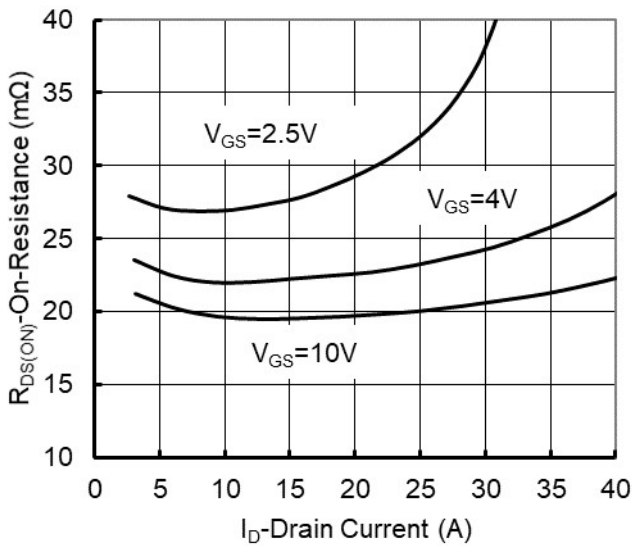

Figure 3: On-Resistance vs. Drain Current and Gate Voltage

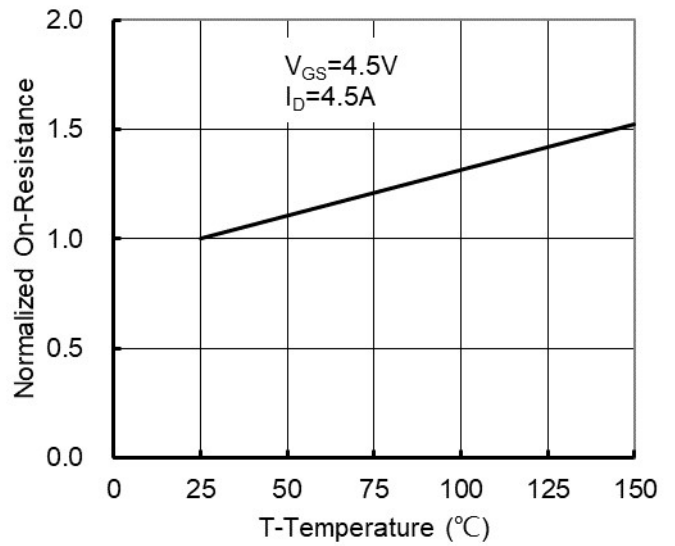

Figure 4: On-Resistance vs. Junction Temperature

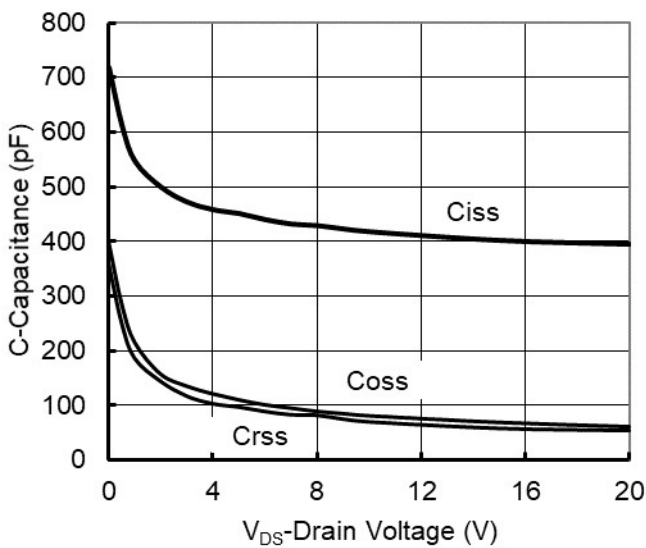

Figure5. Capacitance Characteristics

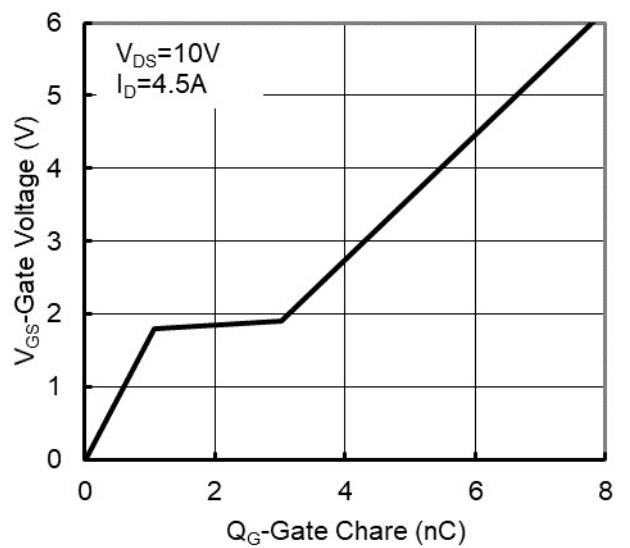

Figure6. Gate Charge

TYPICAL ELECTRICAL AND THERMAL CHARACTERISTICS

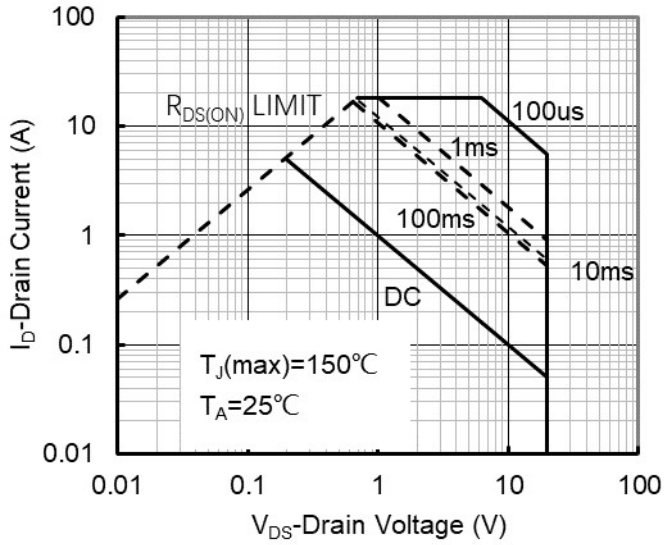

Figure7. Safe Operation Area

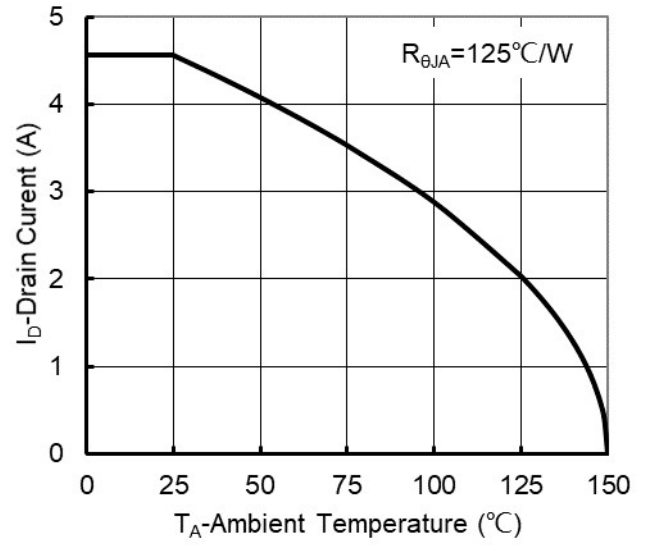

Figure8. Maximum Continuous Drain Current vs Ambient Temperature

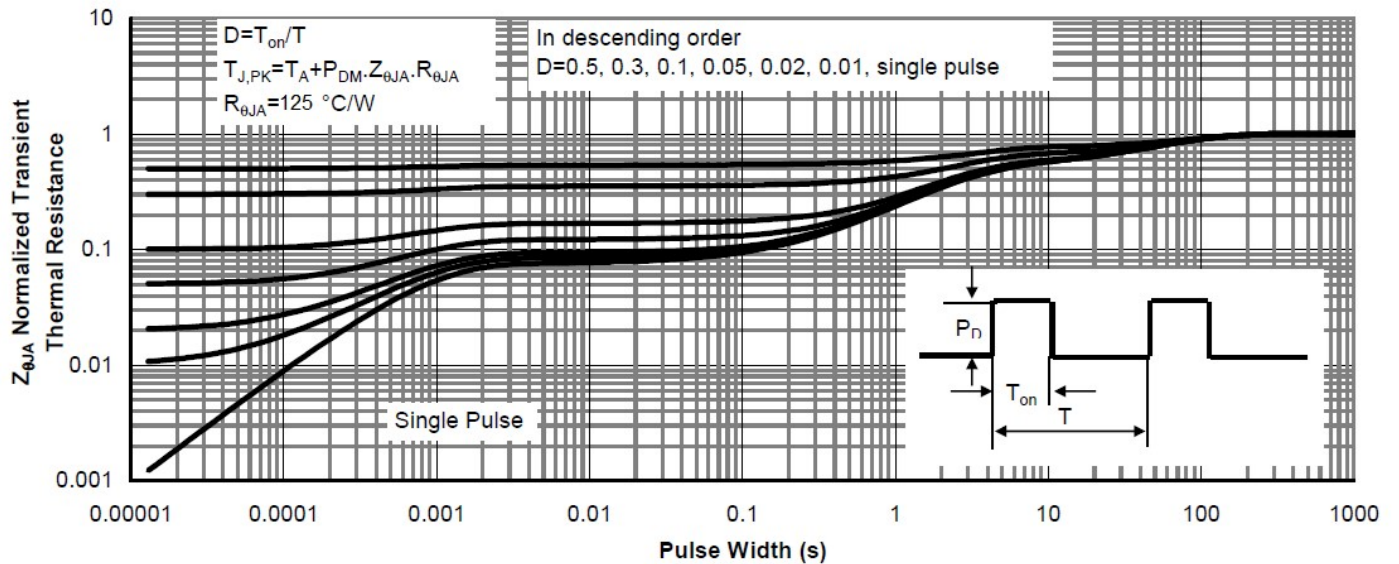
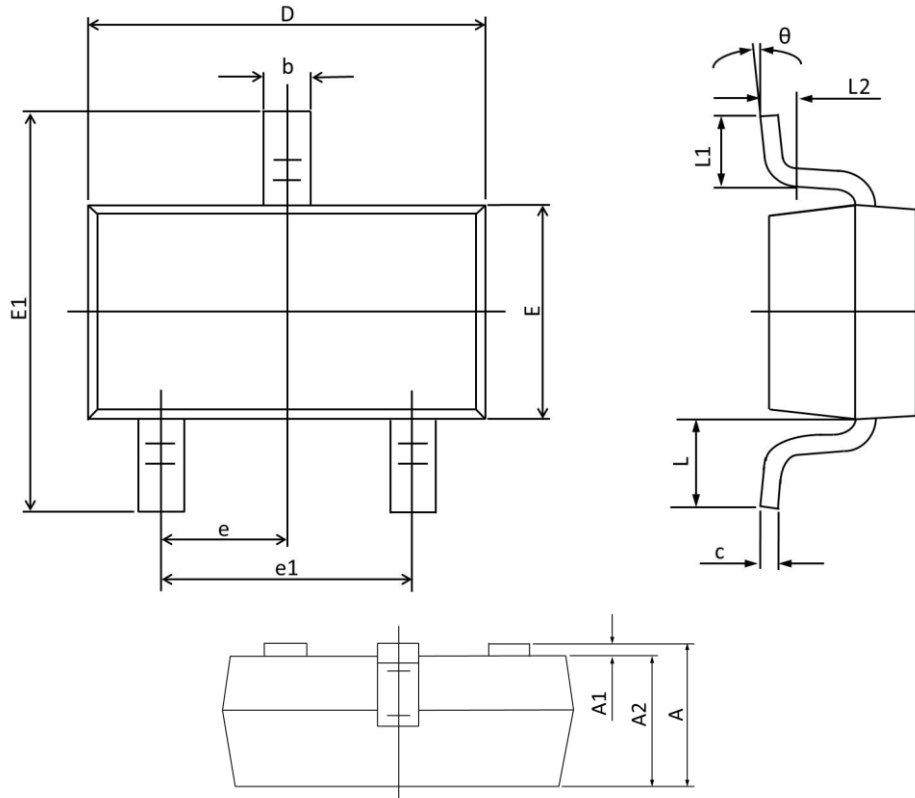

Figure9. Normalized Maximum Transient Thermal Impedance

SOT23 PACKAGE INFORMATION



Symbol	Dimensions In Millimeters		Dimensions In Inches	
	Max	Min	Max	Min
A	1.150	0.900	0.045	0.035
A1	0.100	0.000	0.004	0.000
A2	1.050	0.900	0.041	0.035
b	0.500	0.300	0.020	0.012
c	0.150	0.080	0.006	0.003
D	3.000	2.800	0.118	0.110
E	1.400	1.200	0.055	0.047
E1	2.550	2.250	0.100	0.089
e	0.95 TYP.		0.037 TYP.	
e1	2.000	1.800	0.079	0.071
L	0.55 REF.		0.022 REF.	
L1	0.500	0.300	0.020	0.012
L2	0.25 TYP.		0.01 TYP.	
θ	8°	0°	8°	0°